



Let the Light be Life™

STREET LIGHTING

Solar Street Light **ATIK™**

9W - 1000 Lumen - 12Lux

TECHNOLOGY

The newest solar streetlight **ATIK™** is the latest generation system for road lighting developed by **Istar Solar®** after many years of studies and researches.

This is a very efficient and autonomous system, that can light up streets, crossings, parking areas, gardens and many other places where the grid is missing or where people cannot make excavations or cables connections, with many advantages in comparison with the traditional streetlights with Sox lamp.

The **innovative led lamp with only 3 High Power Chip Leds white light, low consumption, only 9W**, with an average **lifetime of 60.000 hours** is the result of our researches on the field of led lighting.

Thanks to this, we can offer a small system with high performances, reduced weight, space, number of modules, batteries and components needed, and therefore with lower costs.

During the day the PV module produces energy that is stored into the battery. After sunset the energy is used to switch on the led lamp.

Switch on at sunset and switch off at sunrise are automatic by means of a morning-light device already built-in on the charge controller **Istar Solar® Rigel™ 10**.

This **Rigel™ 10** has a microchip to set up the switch off of the lamp after sunset, according to the needs.

The Charge controller **Rigel™ 10** has been properly studied for lighting and for stand alone systems, and is equipped with all main useful functions necessary for a proper functioning of the system : charge controller with check of state of charge of battery, boost and float charge and **morning-light function**.

The streetlight **ATIK™** is very easy to install and it's a very useful efficient and completely autonomous system in case of black out.

The advantages of Istar Solar lighting systems, Led technology:

- Energy saving
- Reduced light pollution
- Reduced environmental impact: the total absence of metal pollutants, RoHS compliance
- Longer lifetime: Led bulbs have a life greatly exceeding 60.000 hours
- Greater uniformity and efficiency
- Best performances immediate switch on and re-ignition time
- Better maintenance of Lumen provision/output over time, compared with traditional lamps
- Road safety : higher real rendering of colors and vibration effect equal to zero
- Cool white light without heat production
- Reduced maintenance
- Green technology: the system is fully independent and works with only the SOLAR LIGHT

ISTAR SOLAR® S.r.l.

Area Industriale Tito Scalco - 85050 Tito Scalco (PZ) ITALY

Tel .+39 0971 485157 Fax +39 0971 651970 E-Mail: info@istarsolar.com Web: www.istarsolar.com



STREET LIGHTING

Solar Street Light **ATIK™**

Let the Light be Life™

Standard configuration of "Atik street light"

The Solar Street Light Atik is composed of:

- N. 2 Photovoltaic Module **IS20P - 20Wp 12V**
- N. 1 Die-cast aluminium lamp Arm with 9W led and electronics equipment
- N. 1 Charge controller Rigel 10 with electronic morning-light function
- N. 1 lead acid dry battery 80Ah 12V
- N. 1 Lamp bracket
- N. 1 Top of pole mount structure, diameter 60mm with adjustable tilt 10°-30°-45°

Outside diameter suggested at the top of pole: **60mm**

Photovoltaic modules to use according to the latitude:

0° - 20°N :	N.1 PV Module IS30P	- 30Wp poli
20° - 30°N :	N.2 PV Module IS20P	- 20Wp poli
30° - 45°N :	N.2 PV Module IS30P	- 30Wp poli
> - 45°N :	N.1 PV Module IS90P	- 90Wp mono

Note: the lighting system are sized to operate around 12 hours per night, with a range of 4/5 days of autonomy without sun. However, in conditions of bad weather and/or not optimal exposure of the modules, the batteries may completely discharge and the lamp will remain off until there are suitable conditions for charging the battery

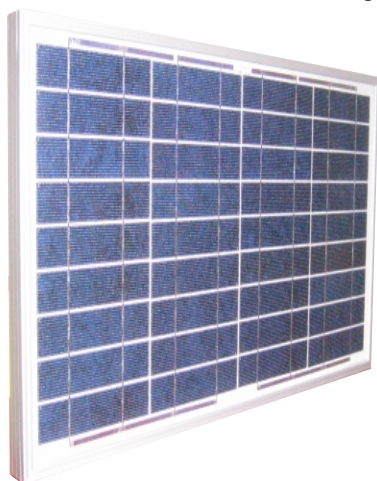

High Power Led White Light	3 LED
Nominal voltage	12 VDC
Color Temperature	K 6.500
Luminous intensity	Lux 12
Luminous in lumen	Lm 1000 (111 Lm/W)
Power consumption	9 Wh
Lifetime of led lamp	>60.000 h
Typical installation Height	6 mt
Diameter of light cone *	24 mt
Operating Temperature	°C from -10 a +50

* See photometrics data

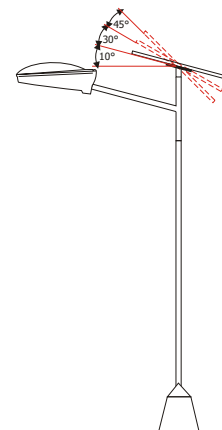

Photometrics Data

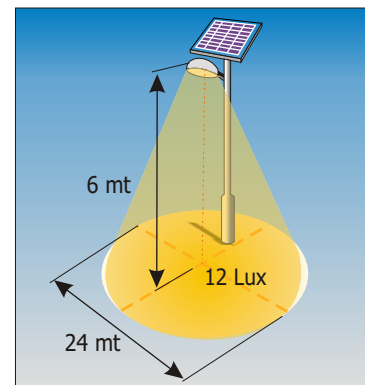
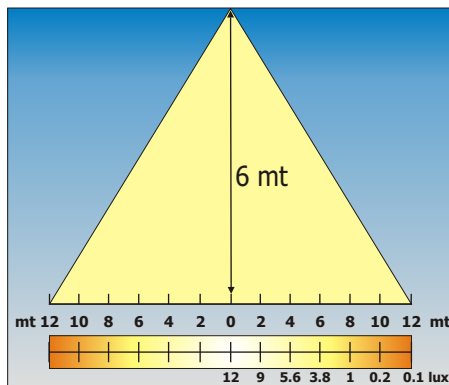
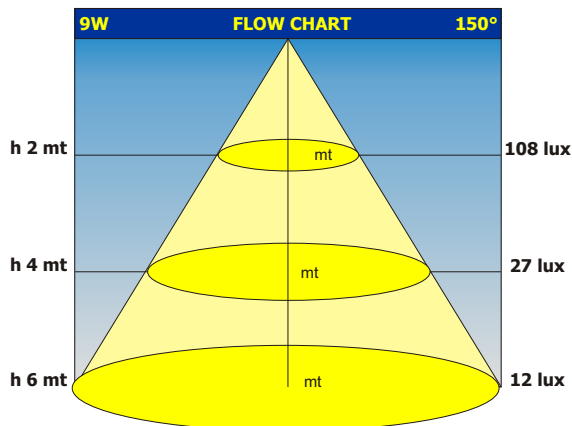

Conformity to: 2006/95/EC - 2004/108/EC directives

Istar Solar® reserves the right to change the products specifications without previous notice



ISTAR SOLAR® S.r.l.

Area Industriale Tito Scalco - 85050 Tito Scalco (PZ) ITALY

Tel. +39 0971 485157 Fax +39 0971 651970 E-Mail: info@istarsolar.com Web: www.istarsolar.com



Let the Light be Life™

STREET LIGHTING

Solar Street Light **ATIK™**

Top of pole mount kit

(for 60mm pole)

Tilt: 10°-30°-45°

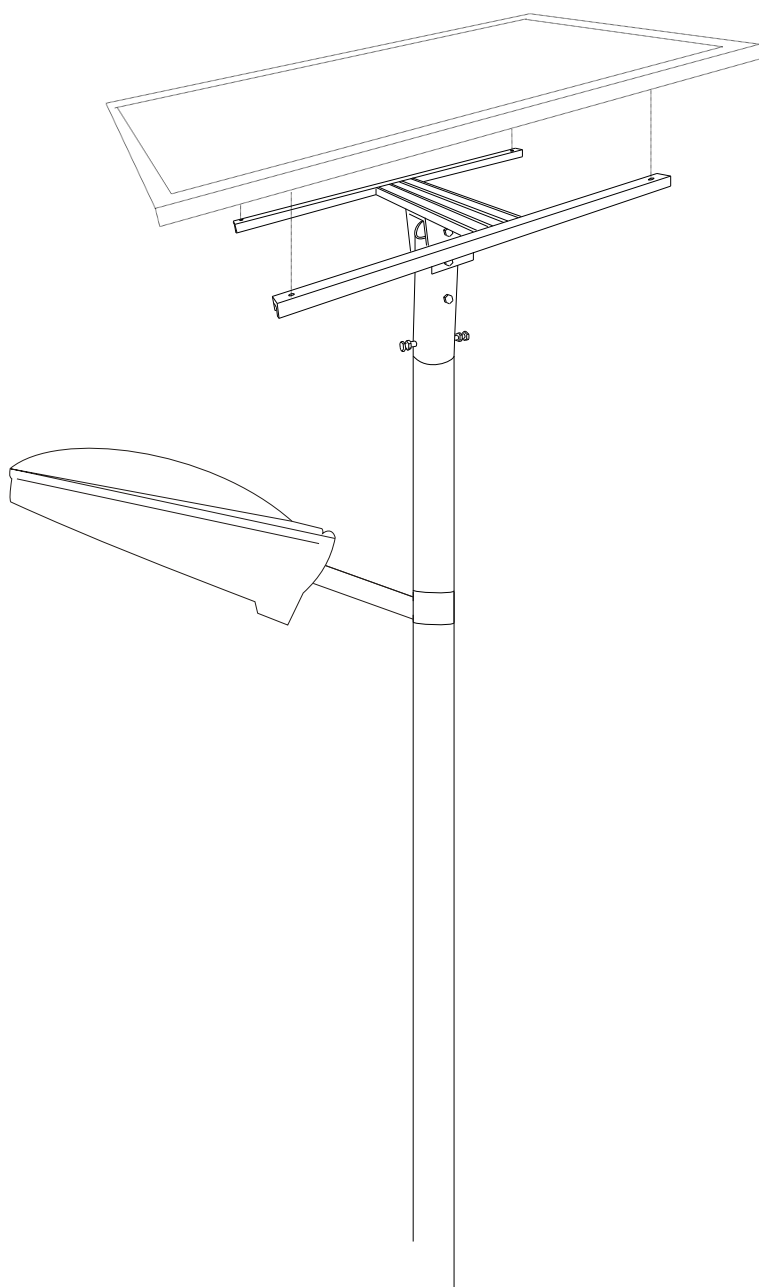
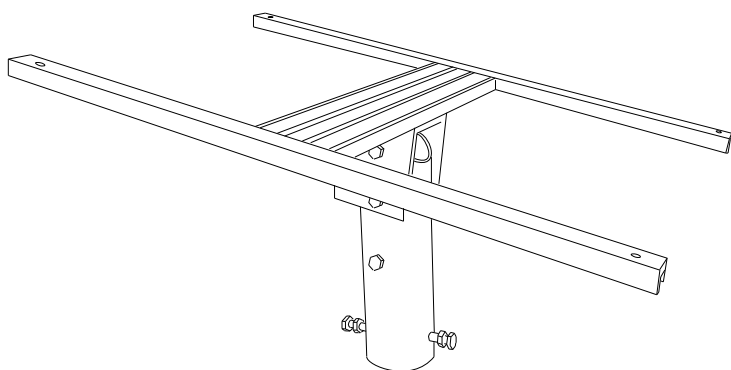

Arm bracket

ISTAR SOLAR® S.r.l.

Area Industriale Tito Scalco - 85050 Tito Scalco (PZ) ITALY

Tel. +39 0971 485157 Fax +39 0971 651970 E-Mail: info@istarsolar.com Web: www.istarsolar.com